

FFOB-570 – Floor Outlet Box General Guide to Installation

A..) Prepare area for installation

1..) Raised Floor

a) Cut aperture (230 x 230mm) in floor at desired location and fix floor box lid & frame directly to floor tile. Order 15-35mm or 35-50mm fixing clamps to suit floor tile depth. Claw type fixings are also available for depths greater than 25mm.

b) Alternatively, cut aperture to fit steel box body and securely fix to tile through sides of box.

2..) Slab/Scree Installation

(See separate guide for blockout/cavity installations where unit secures to cavity wall)

Secure steel box body housing (245 x 230 x 65mm) to structural slab or (recommended option) within preformed recess/blockout. Ensure box body is positioned to finish flush & level with final slab surface and is secured to prevent 'dipping' or 'floating' within screed.

Positioning and securing the box body accurately will prevent operation/installation problems at later stages. Connect conduits to steel box body at desired locations, power to one side – data to the other. Cover opening in box body using temporary cover provided to prevent screed entering box.

B..) Floor Box Lid & Frame Installation

Floor surface (carpet, vinyl etc...) is to be laid first and **trimmed to size of opening in steel box body** ie... cover internal flanges.

Remove lid of floor box assembly as shown below. Floor contractor is then to cut and fit the floor finish into the lid rebate or the optional matching rebate infill is to be affixed.

Fit the FFOB-570 frame into the mounting space created in Step A..) by slackening fixing clamps back to 'One Turn From Off' - then easing the unit into place. Secure the frame by tightening clamps until solid – do not overtighten. The standard clamps supplied with the FFOB-570 fix with floor covering thicknesses of 5mm to 15mm. Clamps for depths up to 50mm are available to order.

Terminate outlets as required (as per AS3000) – clip into moulded plastic outlet casing. Locate cables at strain relief points & tighten strain relief clips.

Ensure plastic outlet casings are securely connected into the floor box frame.

Replace floor box lid and test the operation of the unit.

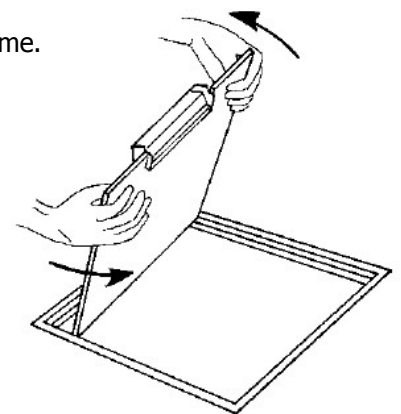
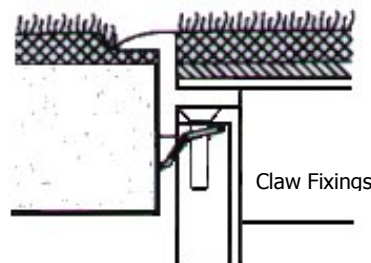
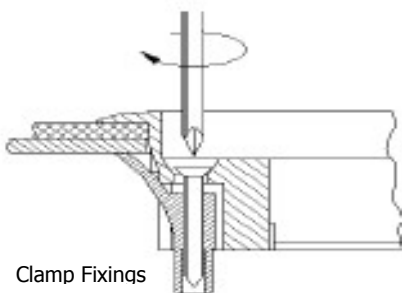

570CS1	- 15-35mm Clamp Set
570CS2	- 35-50mm Clamp Set
570CC	- Claw Type Cavity Fixing Set
570RP	- Lid Rebate Infill

For support please ring...

Tel: Aust. 1300 30 22 49

Tel: NZ 03 379 9283 or 09 525 6051

Assembly Diagram Cat No. FFOB-570

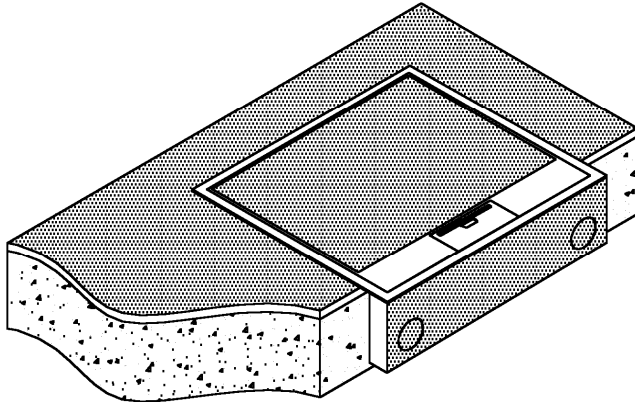

Option - A Foam blockout

Features:

Recommended / Standard Option

Option - B Steel box body

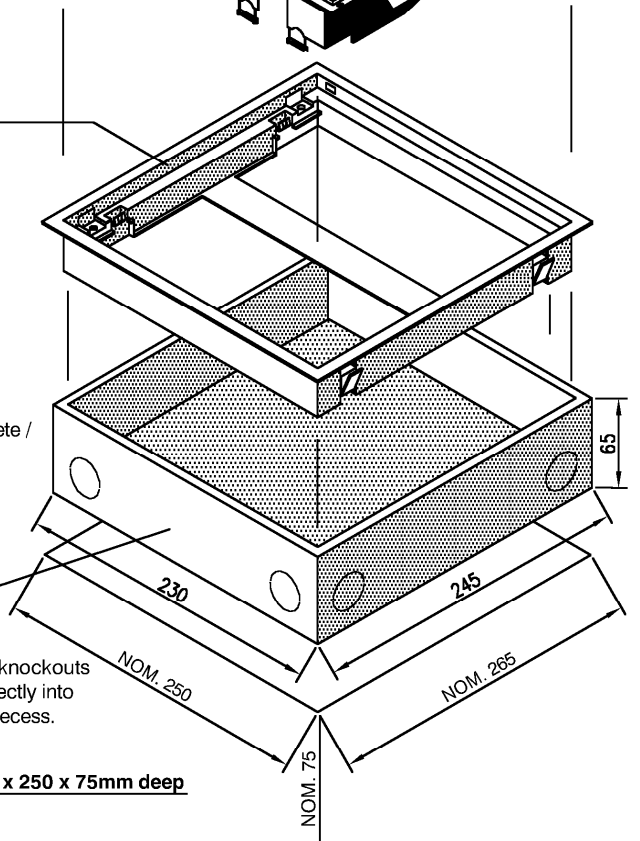
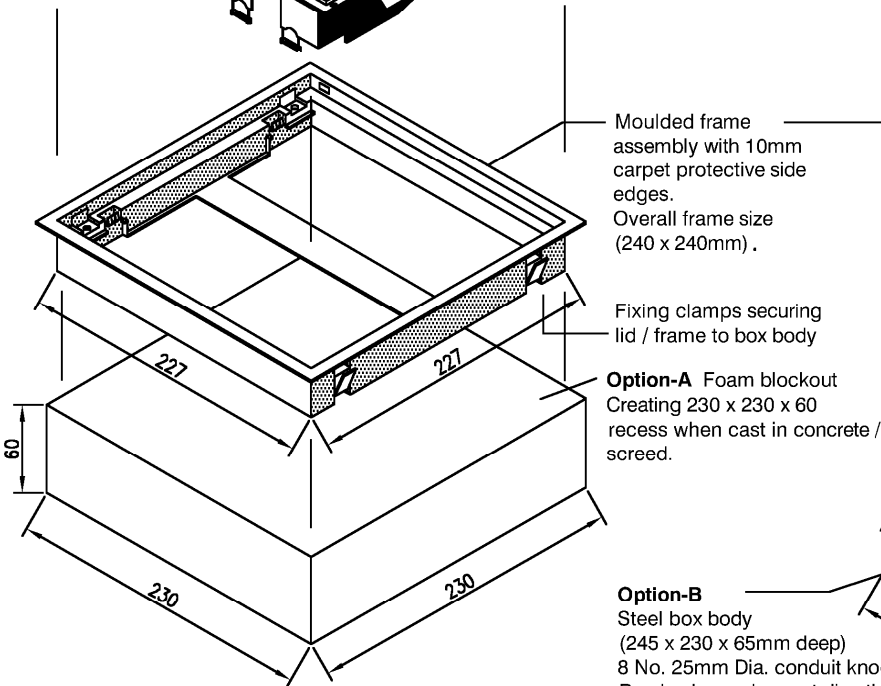
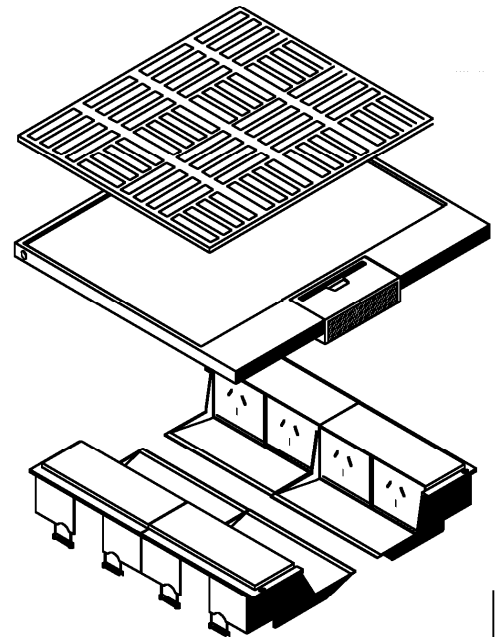
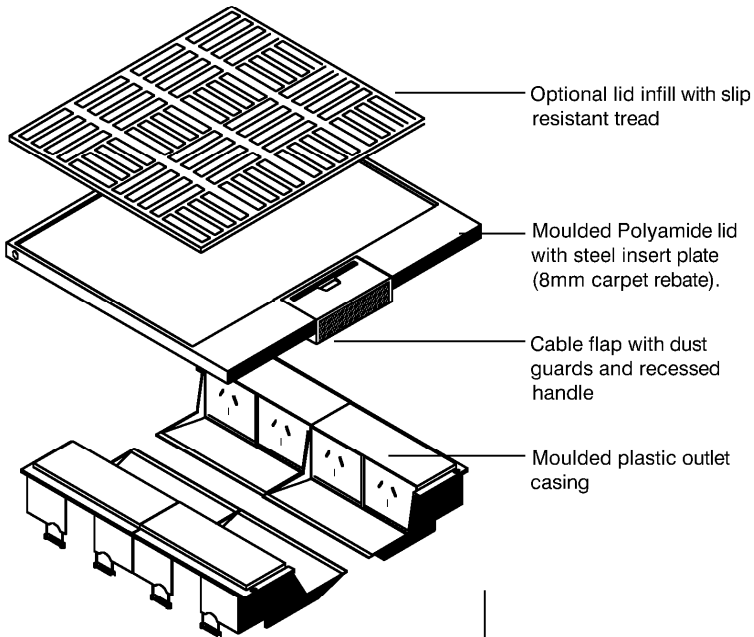

Recess Size: Nom. 265 x 250 x 75mm deep