

At a glance ..

Lid Size	: 325mm (Diameter)
Capacity:	4 autoswitch GPO's & 4 data/voice mechs
Lid Material:	Cast alloy
Colour:	Satin silver (standard) or Polished (to order)
Carpet rebate:	5mm deep
Box Size:	Foam blockout method 308x65mm Steel box method 308x65mm
Recess Size:	Foam blockout method 308x65mm Steel box method 320x85mm

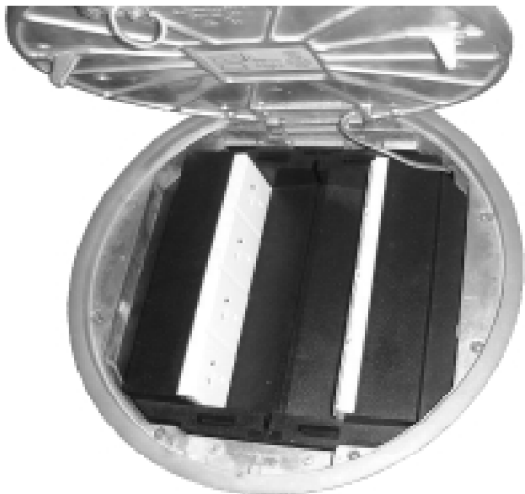

FFOB-595 CAST ALLOY SHALLOW FLOOR BOX

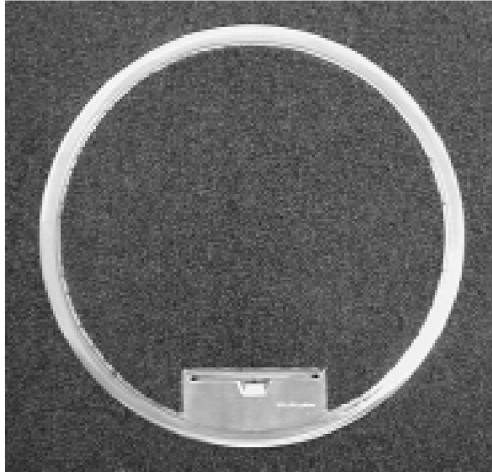

Benefits

Only 65mm deep! For use within shallow screeds over pre-tensioned concrete slabs or where being cut into existing floors.

The hard wearing, load tested* cast alloy lid and frame will withstand the demands of constant operation and regular traffic.

Ideal for use in schools, universities and public buildings.

Will house four autoswitch power outlets and four RJ type data/voice mechanisms.

A circular shape stops the unit from looking out of alignment with walls or furniture.

Installation Features

The lid has a 5mm rebate for carpet or vinyl infill or an optional cast alloy lid rebate infill is available.

The cast alloy lid rebate infill features an attractive tread pattern and should be used where thick timber or stone floor coverings are being laid.

The robust cast alloy cable outlet flap allows cords to exit the box with the lid closed and incorporates a neoprene dustguard and a strong and fully retractable steel handle.

Colours

Supplied with a satin silver finish as standard.

Polished lids and frames are available to order. (Minimum quantities, manufacturing lead times and extra charges may apply).

*VDE 0634 "Ducting and trunking and their accessories for underfloor electrical installations."

VDE is the Association for Electrical, Electronic and Information Technologies (Germany).

Part Number Description

FFOB-595	Electraplan shallow floor box (4 gpo & 4 data mech type)
590D	Satin silver lid rebate infill
595BF	Cut to size foam blockout to suit FFOB-595
595S	Steel box to suit FFOB-595

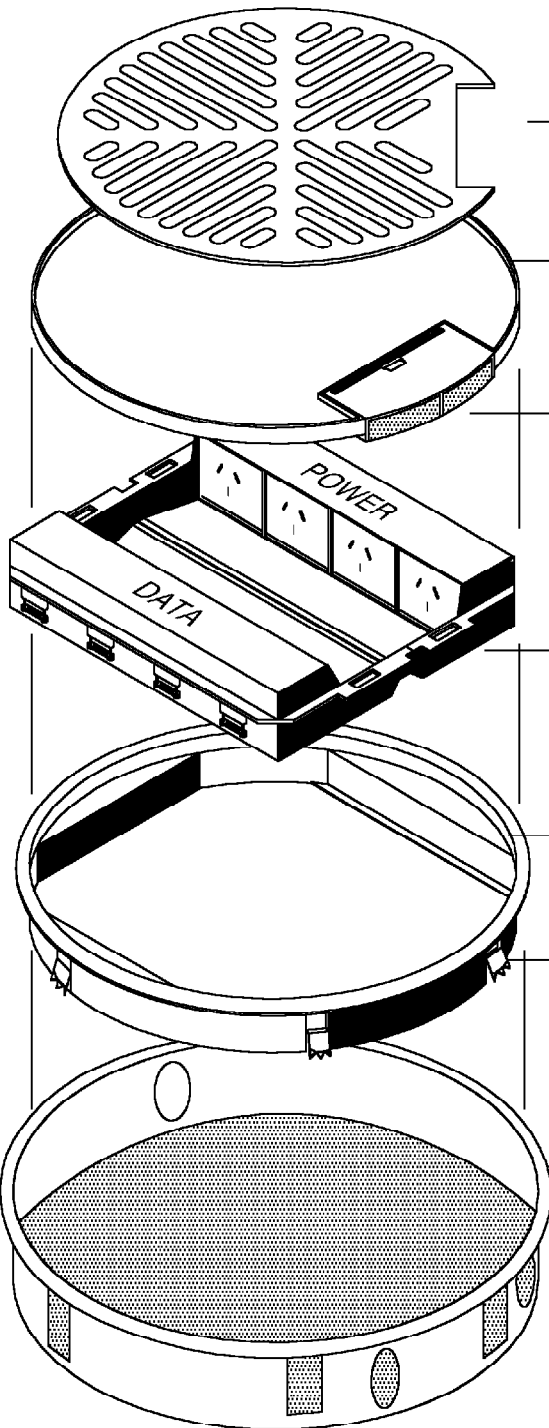

Features:

Optional cast alloy lid infill with slip resistant tread. Available in satin silver finish to match lid and frame set.

Cast alloy lid assembly with 5mm carpet rebate. (Hinges to frame assembly).

Cast alloy cable outlet flap with neoprene dust guards and integrated recessed metal handle.

Maximum outlet capacity
 - 4 No. Auto switched single GPO's
 - 4 No. voice / data outlets

Cast alloy frame assembly with 10mm carpet protective side flanges.
 (325mm Dia.)

Fixing clamps securing lid / frame to box body

Steel canister
 (308mm Dia. x 65mm deep)
 4 No. 25mm Dia. conduit knockouts
 Box body can be cast directly into concrete or a preformed recess.

Recess Size:
Nom. 320 Dia. x 85mm deep